



**Bobcat**<sup>®</sup>

**3400D**

Utility Vehicle



## Machine Rating

Maximum trailer hitch coupler weight	68 kg
Maximum cargo box load	500 kg
Tow weight	680 kg
Vehicle rated capacity	725 kg
Total rated capacity	1406 kg
Max. travel speed — forward (low range)	24 km/h
Max. travel speed — forward (high range)	48 km/h
Max. travel speed — reverse	24 km/h

## Engine

Make / Model	Yanmar 3TNM72-APL
Fuel / Cooling	Diesel / Liquid
Power (SAE J1349) @ 3600 RPM	18.2 kW
Maximum torque at 2500 RPM (SAE J1349)	53.6 Nm
Number of cylinders	3
Displacement	904 cm <sup>3</sup>
Fuel tank capacity	34.1 L

## Weights

Operating weight (full tank + driver)	730 kg
---------------------------------------	--------

## Controls

Vehicle steering	Self-adjusting rack and pinion
Travel speed	Foot pedal. Forward/reverse travel direction is selected by a lever on the dashboard (high/low/neutral/reverse).
Drive modes	Four-wheel drive, two-wheel drive (differential locked), turf (differential unlocked)

## Drive System

Transmission	Torque converter with 6:1 ratio in low range and 3:1 ratio in high range ; CVT (continuously variable transmission)
--------------	---

## Standard Features

Steel frame	Toolkit
Lockable rear differential	Radiator guard
Four-wheel drive	Skid plate to protect undercarriage
Gear selector R-N-L-H	CV guard
Front suspension, MacPherson strut	12 V power outlet
Rear suspension, double A-arm	Beverage holder; glove compartment
Sealed transmission cover	4-wheel, hydraulic brake discs
2 inch rear receiver hitch	3-point seatbelts with comfort strap
Headlights: high and low beam	4-point ROPS
Tail- and brake lights	All-terrain 25 x 11-12 tyres
Headrests	Cargo box with powered lift assist
Parking brake	Warranty: 12 months or 1000 hours (whichever occurs first)
Storage compartment	

## Options

Deluxe version, including:
Brushguard
Black rims
Electric powered cargo box
Dealer Installed Accessories
Modular steel cab
Canvas cab
Plastic canopy
Fixed or tip-out glass windshield
Windshield wiper
Heating
Defroster
Back-up alarm
External mirrors
Internal rear-view mirror
Engine block heater
Working lights
Tum signals
Hom
Strobe lights
Winch
Auxiliary battery
Radio and panel speakers
Brush guard
Exhaust purifier
Chainsaw mount
Cargo box divider
Gas can mount
Vertical tool holder
Horizontal tool holder

## Dimensions

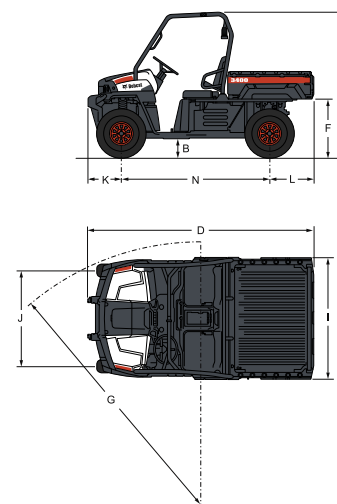

(B)	330 mm	(M)	395 mm
(C)	1905 mm	(N)	545 mm
(D)	2870 mm	(P)	241 mm
(E)	1930 mm	(T)	927 mm
(F)	787 mm		
(G)	1371 x 927 x 292 mm		
(H)	3048 mm		
(I)	3099 mm		
(J)	1524 mm		
	1219 mm		
	1245 mm		



www.bobcat.eu