



Bobcat®

T2556

Telescopic Handlers



Performance

Lifting height	5560 mm
Rated capacity	2500 kg
Capacity at max. height	2500 kg
Capacity at max. reach	1100 kg
Max. reach	3120 mm
Crowding force	3600 daN

Weights

Weight (unladen)	4820 kg
------------------	---------

Traction

Standard tyres	400/70x20 150B
Low speed (forward/reverse)	0–8 km/h
High speed (forward/reverse)	0–30 km/h
Driving modes	Direct drive / soft drive

Drive System

Transmission	Hydrostatic with electronic regulation
Main drive	2-speed hydrostatic motor

Engine

Make / Model	PERKINS / 1104D-44TA Turbo
Fuel / Cooling	Diesel / Water-cooled
Rated power (DIN 6271) at 2200 RPM	74.5 kW (100 HP)
Maximum torque at 1400 RPM	410 Nm
Number of cylinders	4
Displacement	4.4 l

Hydraulic System

Pump type	Gear pump with LS valve
Combined pump capacity	123 l/min
Working pressure	265 bar

Cycle Times

Lift time - no load	6.5 s
Lower time - no load	4.0 s
Telescope in time at max. reach - no load	6.0 s
Telescope in time at max. height - no load	6.0 s
Telescope out time at max. reach - no load	7.0 s
Telescope out time at max. height - no load	7.0 s

Brakes

Engine braking	Hydrostatic
Parking and emergency brake	Negative brake with hydraulic command

Fluid Capacities

Axles and reduction gears front / rear	11.9 / 11.4 l
Engine oil	8.5 l
Fuel tank	115 l
Hydraulic reservoir	77 l

Standard Features

- Aggravating Movements Arrester (AMA)
- Hydrostatic transmission
- ROPS/FOPS operator cab
- Heating, demisting and ventilation
- Front and rear washer/wipers
- Suspension seat
- Two-way hydraulic supply at the end of the boom
- Narrow hook-up for mounting of the equipment
- Mechanical lock of the equipment

Options

- Back-up alarm
- Second hydraulic function on boom
- Cab air conditioning
- Rear hydraulic hook and mirror
- Rotating beacon
- Cooling fan reverser for cleaning purposes
- Rear hydraulic connection
- Trailer brake valve
- Work light on boom
- Set of blue lights for hen houses
- Hydraulic lock of equipment
- Yoke and electrical plug
- Roof windscreen wiper
- Windscreen grill
- Transmission lock override

Load Charts

With forks and TITAN 400/70 x 20 tyres, DUNLOP 400/70x20 140B tyres, DUNLOP 400/70x20 150B tyres & BF GOODRICH 400/70x20 tyres

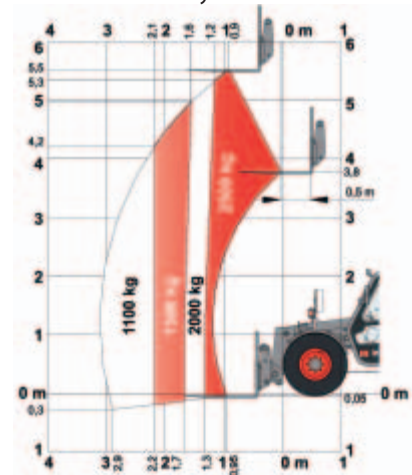

Dimensions

All dimensions in mm.

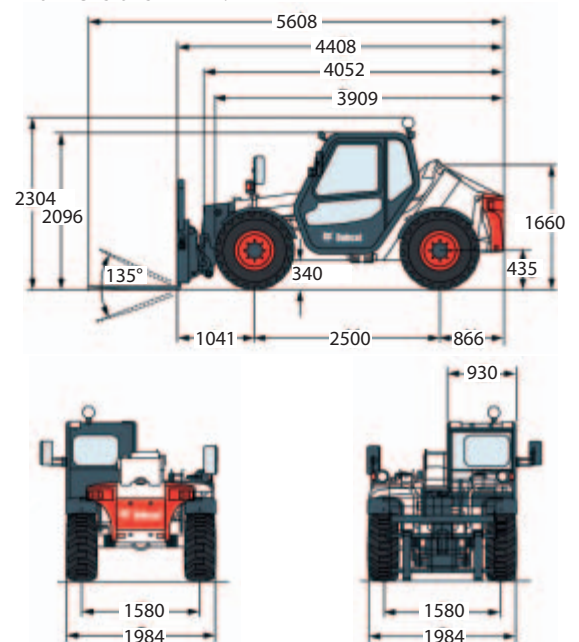

www.bobcat.eu



Bobcat®

Specifications and design are subject to change without notice - Pictures of Bobcat units may show other than standard equipment.