



Bobcat®

E32

Compact Excavators



Standard Features

1520 mm dozer blade	Fingertip auxiliary and offset hydraulic control
320 mm rubber tracks	Horn
Auto idle	Hydraulic joystick controls
Auto shift travel	Lockable storage compartment
Auxiliary hydraulics with Quick Couplers	Radio/MP3 ready
Blade float feature	Retractable seat belt
Cab light	Suspension seat with high back
Clamp ready	* TOPS/ROPS canopy
Control console locks	Two-speed travel
Cupholder	Work lights (boom and upperstructure)
Engine/hydraulic monitor with shutdown	Warranty: 12 months, 2000 hours (Whichever occurs first)

Weights

Operating weight with ROPS canopy	3219 kg
Additional weight for cab with heater	121 kg
Additional weight for cab with HVAC	140 kg
Additional weight for steel tracks	92 kg
Additional weight for long dipperstick	306 kg

Engine

Make / model	Kubota / D1803-M-D1-E3B-BC-3
Fuel / Cooling	Diesel / Liquid, forced circulation
Bore / Stroke	87.0 mm / 102.4 mm
Maximum power at 2400 RPM (SAE J1995)	24.4 kW
Maximum torque at 1400 RPM (SAE J1995)	107.4 Nm
Number of cylinders	3
Displacement	1.862 l

Performance

Digging force, stand. dipperstick	21000 N
Digging force, long dipperstick	18320 N
Digging force, bucket	31500 N
Drawbar pull	34132 N
Ground pressure with standard dipperstick and rubber tracks	29.2 kPa
Ground pressure with standard dipperstick and steel tracks	30 kPa
Ground pressure with long dipperstick and rubber tracks	32 kPa
Ground pressure with long dipperstick and steel tracks	32.8 kPa
Travel speed, low range	2.6 km/h
Travel speed, high range	4.7 km/h
Maximum digging depth, standard dipperstick	3117 mm
(K) Maximum digging depth, long dipperstick	3417 mm

Hydraulic System

Pump type	Single outlet variable displacement, load sensing torque limited pump
Piston pump capacity	100.8 l/min
Gear pump capacity	9.6 l/min
Auxiliary flow	63.9 l/min
Port relief pressure for boom circuits	290 Bar

Fluid Capacities

Cooling system	8.0 l
Engine lubrication plus oil filter	5.2 l
Fuel reservoir	53.1 l
Hydraulic reservoir	9.5 l
Hydraulic system with bucket and dipper cylinder retracted, bucket on the ground, and blade down	39.7 l

Controls

Steering	Direction and speed controlled by two pilot-operated hand levers or two foot pedals
Auxiliary hydraulics	Electric switch in right joystick (left joystick for 2 nd auxiliary)

Slew System

Boom swing, left	77°
Boom swing, right	55°
Slew rate	8.6 RPM

Traction

Track width	320 mm
Gradeability	30°

Working Range

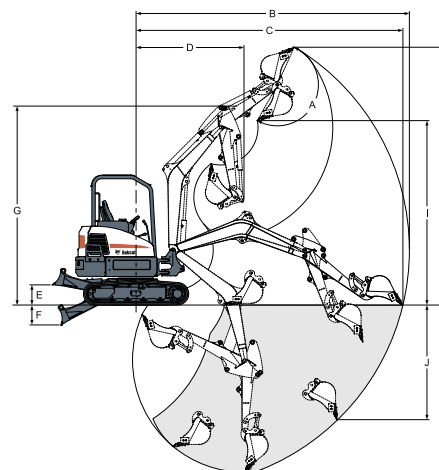

(B)	5383 mm	(G)	3708 mm	(I)	3618 mm
(C)	5270 mm	(H)	4985 mm	(J)	2414 mm
(D)	2077 mm	(E)	376 mm	(K)	3417 mm
(A)	185°	(F)	371 mm	(L)	3437 mm
(B)	5101 mm	(G)	3708 mm	(J)	2136 mm
(C)	4980 mm	(H)	4804 mm	(K)	3117 mm
(D)	2017 mm				

Dimensions

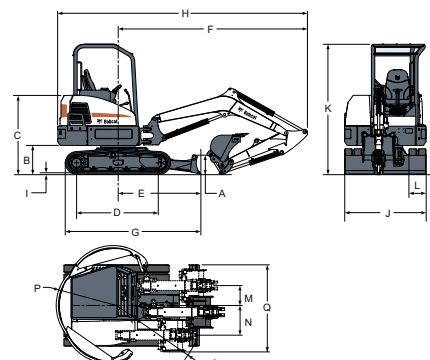

(F)	3546 mm	(H)	4761 mm	(O)	1678 mm
(A)	353 mm	(G)	1964 mm	(M)	371 mm
(B)	537 mm	(H)	4662 mm	(N)	554 mm
(C)	1473 mm	(I)	23 mm	(O)	1623 mm
(D)	1543 mm	(J)	1520 mm	(P)	1125 mm
(E)	1546 mm	(K)	2429 mm	(Q)	1982 mm
(F)	3537 mm	(L)	320 mm		

Options

Air conditioning (Cab with HVAC)	Lifting chain kit
Heating (Cab with heater)	Travel motion alarm
Long dipperstick	300mm Steel tracks
2 nd Auxiliary hydraulics	Beacon kit
Deluxe textile suspension seat	Left and right mirror kit
Boom safety valve with overload warning	Additional work light kit
Boom & arm safety valves with overload warning	Rubber bolt-on pads for steel tracks
AM/FM MP3 stereo radio	Special applications kit (Front windscreen protection)
FOGS kit (Overhead guard)	Fuel filter with transparent water separator

Attachments

Auger	Digging bucket
Grading bucket	Tilt rotator
Hydraulic breaker	Tilt buckets / Swivel buckets
Hydraulic clamp	



www.bobcat.eu