

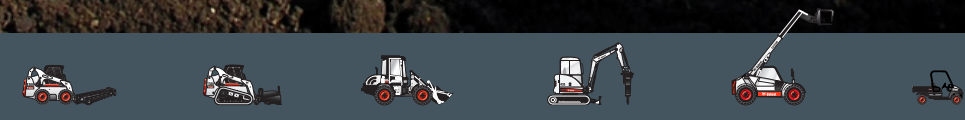

Bobcat®

425

Compact Excavators



Standard Features

1540 mm dozer blade	Hydraulic joystick controls
320 mm rubber or steel tracks	Retractable seat belt
Auxiliary hydraulics with Quick Couplers	Spark arrester muffler
Blade float feature	Suspension seat with high back
Control console locks	* TOPS/ROPS canopy
Cupholder	Two-speed travel
Engine/hydraulic monitor with shutdown	Vandalism protection
Fingertip auxiliary hydraulic control	Working lights
Horn	Warranty: 12 months, 2000 hours

Weights

Operating weight with ROPS canopy	2604 kg
Additional weight for cab with heater	47 kg
Additional weight for steel tracks	72 kg

Engine

Make / model	Kubota / V1505-E3B-BC-2
Fuel / Cooling	Diesel / Liquid, forced circulation
Bore / Stroke	78.0 mm / 78.4 mm
Maximum power at 2300 RPM (DIN 70020)	18.8 kW
Maximum torque at 1600 RPM (SAE J1349 Gross)	90.6 Nm
Number of cylinders	4
Displacement	1.5 l

Performance

Digging force, dipperstick	14600 N
Digging force, bucket	22500 N
Drawbar pull	25872 N
Ground pressure with rubber tracks	24.4 kPa
Ground pressure with steel tracks	25.5 kPa
Travel speed, low range	2.1 km/h
Travel speed, high range	3.7 km/h
Maximum depth of vertical wall which can be excavated	1654 mm

Hydraulic System

Pump type	Dual-outlet, variable displacement piston pump
Piston pump capacity	55.2 l/min
Auxiliary flow	50 l/min
System relief pressure for boom and bucket circuits	230 Bar

Fluid Capacities

Cooling system	8.1 l
Engine lubrication plus oil filter	5.5 l
Fuel reservoir	67.4 l
Hydraulic reservoir	9.1 l
Hydraulic system with bucket and dipper cylinder retracted, bucket on the ground, and blade down	20.7 l

Controls

Steering	Direction and speed controlled by two pilot-operated hand levers or foot pedals
Auxiliary hydraulics	Electric switch in right joystick

Slew System

Boom swing, left	90°
Boom swing, right	50°
Slew rate	9.9 RPM

Traction

Track width	320 mm
Gradeability	30°

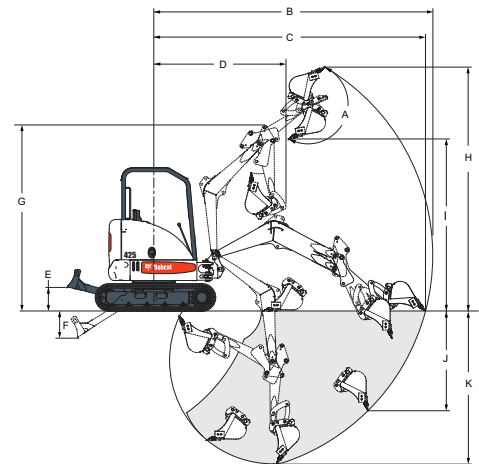
Working Range

(A)	185°	(E)	390 mm	(I)	2862 mm
(B)	4521 mm	(F)	446 mm	(J)	1654 mm
(C)	4639 mm	(G)	3096 mm	(K)	2541 mm
(D)	2199 mm	(H)	4063 mm		

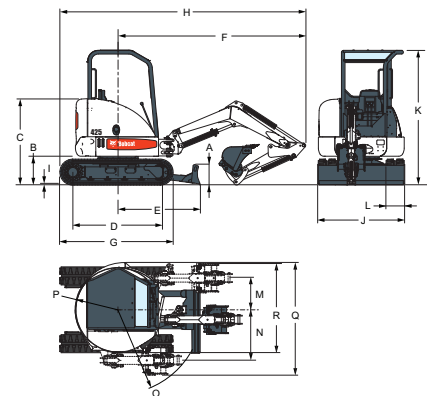
Dimensions

(A)	359 mm	(G)	2005 mm	(M)	561 mm
(B)	512 mm	(H)	4351 mm	(N)	896 mm
(C)	1531 mm	(I)	25 mm	(O)	1486 mm
(D)	1563 mm	(J)	1540 mm	(P)	756 mm
(E)	1455 mm	(K)	2392 mm	(Q)	1912 mm
(F)	3320 mm	(L)	320 mm		

Options

AM/FM stereo radio	Keyless start
Bobcat™ Quick Coupler (BQC) type K	Lifting chain kit
Bobcat™ Quick Coupler (BQC) type SW	Special applications kit
Bolt-on counterweight	Steel tracks
Cab enclosure, vinyl	TOPS/ROPS cab with heater
Catalytic exhaust purifier kit	Travel motion alarm
FOPS kit	X-Change™ attachment mounting system

Attachments

Auger	Hydraulic clamp (not recommended)
Cutter crusher	Plate compactor
Grading bucket	PowerTilt®
Grapple	Ripper
Hydra-Tilt	Trenching bucket
Hydraulic breaker	Trencher



www.bobcat.eu