

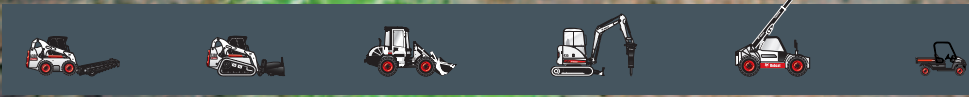

Bobcat®

Planer

Attachments



A Bobcat loader becomes an efficient, cost-effective planing machine

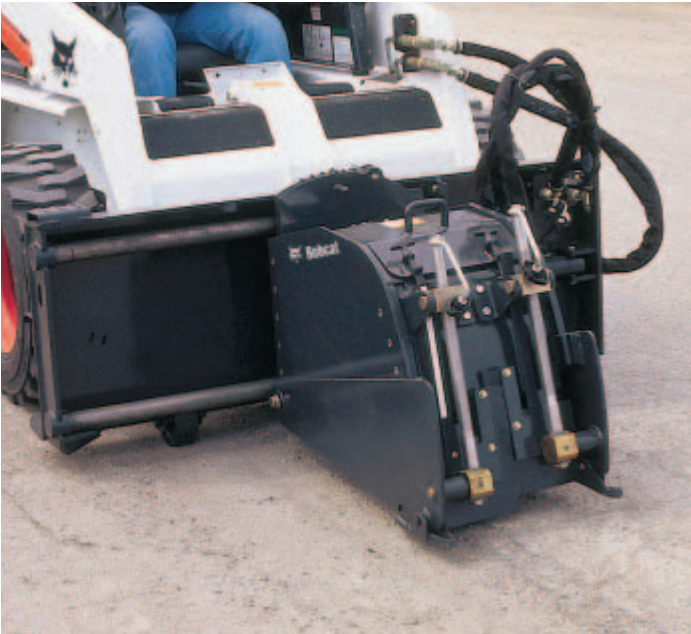

Bobcat 14"/36 cm Standard-Flow Planer

An economy model designed to work well on specified Bobcat loaders. The standard-flow planer is a perfect attachment for municipalities and road repair crews doing minor repairs on parking lots, driveways and roads. The 14"/36 cm drum and manual depth adjustment are ideal for milling potholes, cracks and other damages. An optional hydraulic depth control kit is available to upgrade standard-flow planers to fingertip control of the planer skis.



Bobcat 18"/45 cm and 24"/61 cm High-Flow Planers

Provide additional versatility and productivity with more features and independent controls, utilizing the high-flow hydraulics of the Bobcat loader. Bobcat high-flow planers are invaluable tools for many asphalt and concrete repair jobs, including matching uneven pavement surfaces, cutting drainage in parking lots, street repairs and cleanup around larger milling machines.

chine with a Bobcat planer attachment.



Bobcat 40"/100 cm High-Flow Planer

This planer delivers the highest performance in the range and offers three unique features:

- Hydraulic oscillation controlled from the operator seat
- Front and rear self-levelling helps skis maintain full surface contact regardless of the tilt cylinder extension
- Two direct-drive motors, one on each side of the drum

This planer is standard-equipped with an all-purpose drum, hose kit and seven-pin control harness. The operator has fingertip control of the side-shift, individual ski depth and oscillation.



Bobcat 16"/41 cm Surface Planer

Designed to produce very fine surface finishes. The Bobcat surface planer attachment removes lines, paint stripes and thermoplastics from parking lots, highways, streets and airports. New paint or thermoplastics can be poured into the recessed areas after planing, leaving stripes and lines untouched by snowplows. Dairy barns and other concrete surfaces can be roughed to prevent slipping and improve traction. The surface planer uses a high-speed motor and a specially designed 16"/41 cm drum with 184 bits, ensuring a smooth surface finish while allowing the operator to travel at speeds up to 7-14 m per minute.

Bobcat 14", 16", 18" and 24" Planer Features:



The **ski wear pads** are replaceable and provide consistent depth control by penetrating through debris in the path of travel. Optional planer wheel kit available to replace skis.



Dual cylinders, independently adjustable, provide depth control for each ski.**



The high-flow planer attachment utilizes a **priority valve** to divert oil to depth functions without causing momentary loss of power to the planer drum; this allows the operator to make adjustments on the go.**



The **oscillation** of the planer provides optimum surface tracking and isolating the planer from loader movements caused by uneven terrain. Adjustable depth skis allow tapering of cut, such as when matching two uneven pavement surfaces or removing a curb ridge.



The **planer housing** oscillates $\pm 15^\circ$ for cutting at an angle or matching uneven surfaces. An indicator is provided with markings locating each $\pm 5^\circ$ of oscillation. If desired, it may be put in a locked position.



The **depth of the skis** is indicated by a depth gauge visible from the operator seat.



The **top access service panel** is of sufficient size to replace the cutting bits without raising the planer from the surface or removing the drum.



Steel wheels mounted on the rear frame help support the planer when starting a cut and while planing.

** Hydraulic depth control is an option on 14"/36 cm planers.

Bobcat 14", 16", 18" and 24" Planer Features:



The **right ski and end plate** are removable to allow flush milling against curbs or walls (14", 16", 18" and 24" drum). Side cutting bits decrease drum binding and provide a vertical edge for improving the joint bond.

Bobcat 40" Planer Features:



Use the diverter valve control to switch between hydraulic side-shift and hydraulic oscillation.

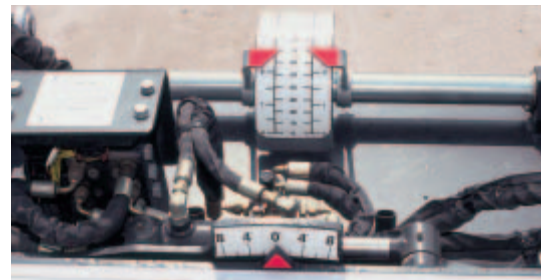

Individual ski depth gauge and oscillation gauge are easily visible from the operator seat.

Bobcat Planer Accessories:



The optional **water kit** provides dust control.



Optional guide rod available for 14", 16", 18" and 24" Bobcat planers; helps the operator maintain a straight cut.

Benefits

Equipped with direct-drive, high-torque hydraulic motors, these low maintenance attachments efficiently mill asphalt or concrete. The planers feature hydraulic side-shift for planing close to walls and curbs. Consistent depth control and ski depth visible from the operator seat. Make precise adjustments with fingertip controls.

Applications

- Construction
- Road repairs

Approved machines

	14" / 36 cm Standard-Flow Planer	18" / 45 cm High-Flow Planer	24" / 61 cm High-Flow Planer	40" / 100 cm High-Flow Planer	16" / 41 cm Surface Planer
Approved for loaders:	S130, S150, S160, S175, S185, S205, S220, S250, S300, A300, T140, T190, T250, T300	S160H, S175H, S185H, S205H, S220H, S250H, S300H, A300H, T190H, T250H, T300H	S160H, S175H, S185H, S205H, S220H, S250H, S300H, A300H, T190H, T250H, T300H	S220H, S250H, S300H, A300H, T250H, T300H	S160H, S175H, S185H, S205H, S220H, S250H, S300H, A300H, T190H, T250H, T300H

Weights and dimensions

	14" / 36 cm Standard-Flow Planer	18" / 45 cm High-Flow Planer	24" / 61 cm High-Flow Planer	40" / 100 cm High-Flow Planer	16" / 41 cm Surface Planer
Operating weight (kg)	662	701	805	1043	723
Overall width (mm)	1651	1651	1651	1727	1651
Overall height (mm)	711	711	711	813	711
Overall length (mm)	1278	1278	1278	1118	1278

Performance

	14" / 36 cm Standard-Flow Planer	18" / 45 cm High-Flow Planer	24" / 61 cm High-Flow Planer	40" / 100 cm High-Flow Planer	16" / 41 cm Surface Planer
Cutting width (with std drum) (mm)	356	457	610	1016	406
Cutting depth (with std drum) (mm)	0 – 152	0 – 152	0 – 152	0 – 130	0 – 152
Max. oscillation angle (°)	± 15	± 15	± 15	± 8	± 15
Side-shift (mm)	660	660	660	650	660
Planing distance next to curb (mm)	flush	flush	flush	65	flush

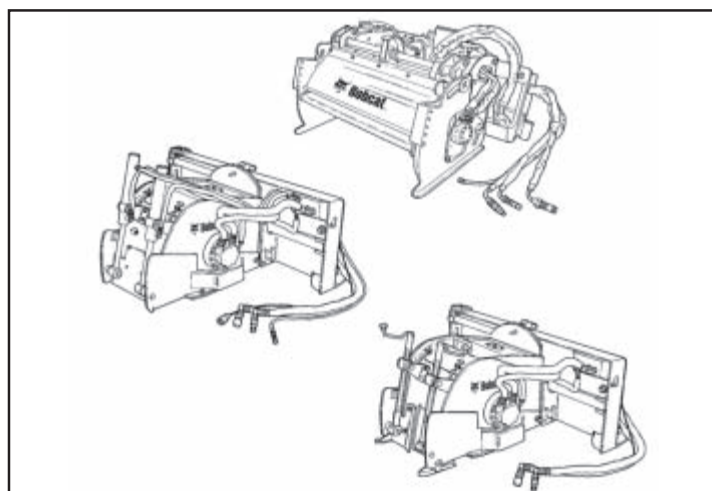

www.bobcat.eu