



Bobcat®

E08 – E10

Compact Excavators



E08 Micro-Excavator

- Retractable undercarriage and blade
- Foldable TOPS structure
- Built-in operator safety
- Compact dimensions
- Cylinder-over-the-boom design
- Optional Demolition Kit for additional cooling
- Easy access to daily maintenance points



Ideal for applications where larger machines cannot fit.

■ Powerful and productive

These versatile micro-excavators pack a big punch, whether used for demolition or landscaping work. Thanks to short tail swing, they are less likely to get damaged while working, thus providing a longer service life and lower total cost of ownership.

For work with a breaker, the optional demolition kit for both the E08 and E10 provides additional cooling to allow the machines to keep working longer.

■ Stable and compact

The expandable undercarriage ensures unmatched stability for this size of machine, while retracting easily to allow the excavator to pass through narrow openings. Combined with the integrated, foldable TOPS, it means that 710 mm wide, low-headroom openings are no barrier to these machines!

■ Comfortable and convenient

Low noise and vibration levels ensure excellent operator comfort along with reduced environmental impact. The adjustable joystick controls on the E10 take comfort to unequalled levels.

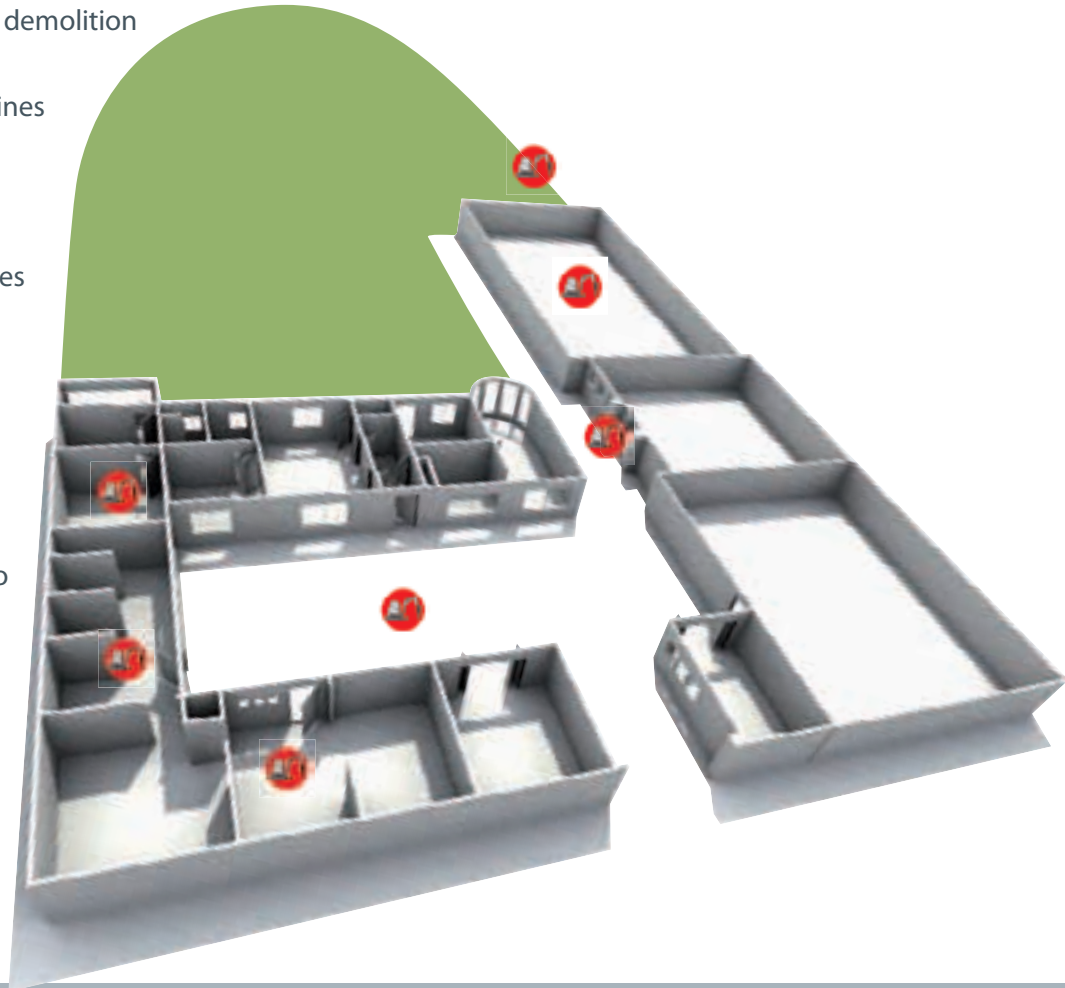

The E08 and E10 are both equipped with expandable undercarriage and blade as standard. There is no need to remove and reinstall the blade extensions.



Both models are equipped with a foldable TOPS structure.

E10 Micro-Excavator

- Zero tail swing (ZTS) design
- Unique adjustable hydraulic joystick controls
- 2-speed operation
- Retractable undercarriage and blade
- Foldable TOPS structure
- Built-in operator safety
- Compact dimensions
- Cylinder-over-the-boom design
- Optional Demolition Kit for additional cooling
- Easy access to daily maintenance points



Unique adjustable joystick controls on the E10 provide unmatched operator comfort.

Easy to transport

As well as being able to pass through narrow, low-headroom openings, the Bobcat E08 and E10 micro-excavators are also easy to transport.



With easy access to the engine and hydraulic systems, maintenance is quick and simple.



	E08	E10
Weights		
Operating weight with TOPS structure	1138 kg	1176 kg

Engine		
Make / model	Kubota / D722-E2B-BCZ-6 (TIER 2)	
Fuel / Cooling	Diesel / Liquid	
Maximum power at 2000 RPM (ISO 9249)	7.4 kW	
Torque at 1600 RPM (SAE Net)	39.1 Nm	
Number of cylinders	3	
Displacement	0.72 l	
Bore / Stroke	67 mm / 68 mm	
Alternator	12 V — 40 A	
Starter	12 V — 1.4 kW	

Controls		
Steering	Direction and speed controlled by two hand levers	
Hydraulics	Two levers control boom, bucket, dipperstick and upper structure slew	Two joysticks control boom, bucket, dipperstick and upper structure slew

Hydraulic System		
Pump type	Double gear pump	
Pump capacity	2 x 10 l/min @ 2000 RPM	
Auxiliary flow	20 l/min	
System relief pressure for implement circuits	185 bar	190 bar
System relief pressure for auxiliary circuits	185 bar	190 bar
Control valve	Nine-spool parallel type, open centre	

Performance		
Digging force, dipperstick	5550 N	
Digging force, bucket	8294 N	
Drawbar pull	9905 N	
Ground pressure	28.8 kPa	29.7 kPa
Travel speed (low range)	2.1 km/h	
Travel speed (high range)	— km/h	3.1 km/h
Maximum digging depth	1820 mm	

Slew System		
Boom swing, left	70°	
Boom swing, right	70°	
Slew circle	Single row shear-type ball bearings with internal gear	
Slew drive	Orbit motor	
Slew rate	9 RPM	

Traction		
Track width, rubber, standard	180 mm	
Number of track rollers per side	3	
Gradeability travelling down or backing up slopes	30°	

Brakes		
Travel brake	Hydraulic lock in motor circuit	
Slew brake	Hydraulic lock on motor and pin lock	

Fluid Capacities		
Cooling system	3.0 l	
Engine lubrication plus oil filter	3.5 l	
Fuel reservoir	16.0 l	
Hydraulic reservoir	2.6 l	
Hydraulic system	9.4 l	10.1 l

Working Range
All dimensions in mm.

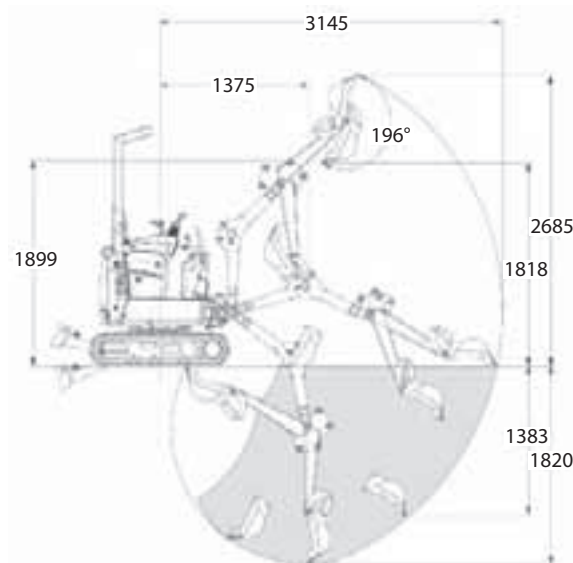

Dimensions
All dimensions in mm.

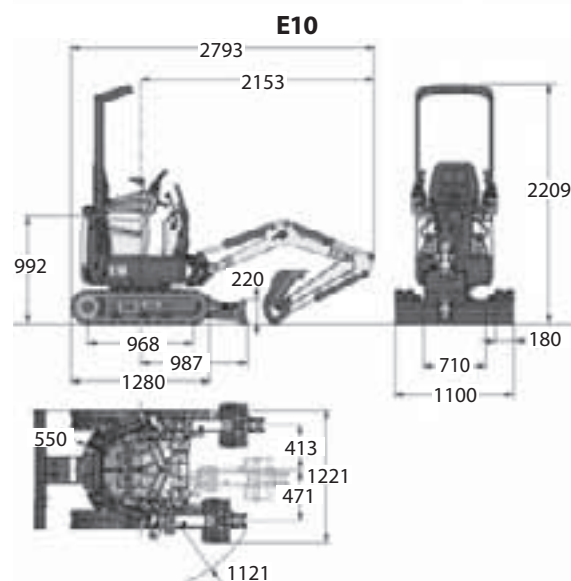
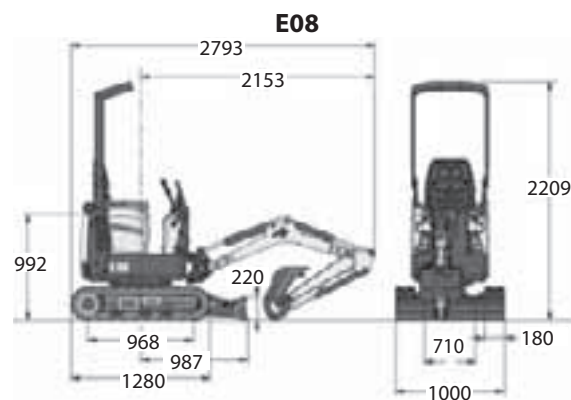

www.bobcat.eu



Bobcat®

Specifications and design are subject to change without notice - Pictures of Bobcat units may show other than standard equipment.

