



Bobcat®

TR35160

Telescopic Handlers



Performance

Lifting height — on stabilisers	15700 mm
Lifting height — on tyres	15500 mm
Rated capacity	3500 kg
Capacity (at max. height — on stabilisers)	2000 kg
Capacity (at max. height — on tyres)	1700 kg
Capacity (at max. reach — on stabilisers)	300 kg
Capacity (at max. reach — on tyres)	300 kg
Max. reach — on stabilisers	13350 mm
Max. reach — on tyres	13350 mm

Weights

Weight (unladen)	13100 kg
------------------	----------

Traction

Standard tyres	18 — R22.5in
Optional tyres	none
Low speed (forward/reverse)	9 km/h
High speed (forward/reverse)	24 km/h

Drive System

Transmission	Hydrostatic with electronic regulation
Main drive	2-speed hydrostatic motor

Engine

Make/Model	IVECO / NEF F4GE054A-TC
Fuel / Cooling	Diesel / Liquid
Rated power (DIN 6271) at 2200 RPM	74 kW (102 HP)
Maximum torque at 1400 RPM	410 Nm
Number of cylinders	4
Displacement	4.485 l

Hydraulic System

Pump type	Single gear pump
Working pressure	230 bar

Function Time

Lift time — no load	23.0 s
Lower time — no load	19.0 s
Telescope in time at max. reach — no load	25.0 s
Telescope in time at max. height — no load	21.0 s
Telescope out time at max. reach — no load	31.0 s
Telescope out time at max. height — no load	29.0 s

Brakes

Engine braking	Hydrostatic
Parking brake	Negative brake with electro-hydraulic command on rear axle

Fluid Capacities

Axles and reduction gears front/rear	10 / 10 l
Engine oil	9 l
Fuel tank	126 l
Hydraulic reservoir	270 l

Standard Features

Man platform ready	Front and rear washer/wipers
Hydrostatic transmission	Suspension seat
Two way hydraulic supply at the end of the boom	Road lights
Back-up alarm	
Boom stop	
Lockable fuel cap	
Heating, demisting and ventilation	
Carriage with manual attachment lock	
ROPS/FOPS operator cab	

Options

Special painting	Cold weather kit
Pneumatic seat (compulsory with double joystick)	Cold start (engine water heater)
Carriage with hydraulic attachment lock	Webasto heater (Cold weather kit is compulsory)
Controls with double joystick	Pallet fork transversal block
Remote control	Anti-theft immobiliser
Second auxiliary hydraulic line with electrical line	Catalytic exhaust purifier
Work light on top of cabin	Centering handler and positive/negative jib pre-arrangement
Air conditioning	
Boom light	TÜV homologation
Radio	Under chassis protection
Radio with CD player	2-speed accelerator adjustment for remote control
Protective grill for windshield	Electronic accelerator adjustment for remote control
Limited slip differential for rear axle	Cold start (engine air heater)
Electric contact on boom head	Auto-cleaning air prefilter

Load Charts

On stabs, with forks, 90 degrees

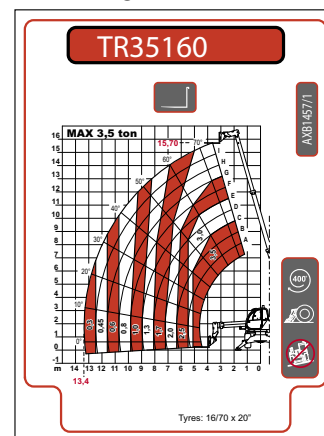

Dimensions

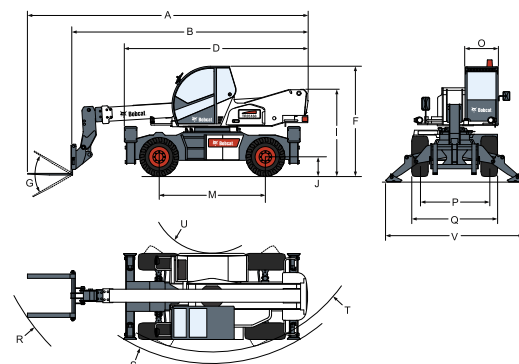

(A)	7840 mm	(G)	134°	(M)	2950 mm
(B)	6350 mm	(I)	2430 mm	(O)	980 mm
(D)	4880 mm	(J)	340 mm	(P)	1920 mm
(F)	3000 mm			(Q)	2380 mm
				(R)	6230 mm
				(S)	4750 mm
				(T)	4430 mm
				(U)	1700 mm

Specifications and design are subject to change without notice - Pictures of Bobcat units may show other than standard equipment.



www.bobcat.eu