



3400D | Utility Vehicle



Driven to perform

The Bobcat utility vehicle delivers the best possible performance and productivity in its class. If you're driven to do more in a day, Bobcat delivers the muscle, traction and options you need to take on a larger variety of jobs.

■ Exceptional horsepower

More horsepower means you can get more done in a day. Thanks to high increased wheel torque, plenty of speed, better acceleration and extra power for a high payload. Working with a 4x4 vehicle, you'll get better performance pulling through challenging ground.

■ Speed for the job

Spend less time moving from place to place and more time doing the job. A top speed of 48 km/h and the ability to quickly reach that top speed will rapidly get you, and your cargo, to the jobsite.

■ Ample payload

High horsepower, leading-edge suspension and strong brakes add up to higher payloads – up to 1406 kg total rated capacity – so you can carry more in fewer trips.



Keep on driving

■ Two-speed transmission

Low-range operation gives you maximum wheel torque for heading uphill or towing heavy loads. High range provides top speed when driving on hard-packed surfaces under light loads. With the 3400D, you select the range you need for the task.

■ Variable-rate acceleration

Variable-rate acceleration allows the machine to increase speed at a slower rate through the first half of the pedal stroke – giving you precise control of travel speed when manoeuvring around trees, walls and gates. During the second half of the pedal stroke, it responds at a faster rate to quickly reach its top speed of 48 km/h.

■ Independent wheel suspension

Improve agility over rough terrain. The 3400D utility vehicle offers advanced independent wheel suspension to improve your comfort and keep the wheels in contact with the ground for maximum traction.



Drive Mode Selection

Match the drive mode to the conditions around you at the touch of a button:

- TURF MODE: open rear differential, allows the wheels to turn at different speeds, resulting in minimal ground disturbance as you turn.
- TWO-WHEEL DRIVE: locked rear differential, provides equal torque to both rear wheels for better traction.
- FOUR-WHEEL DRIVE: provides optimum torque to every wheel. If the rear wheels start to lose traction, the front wheels engage to power you through the slippery terrain.

A good steed needs good armour

There's no telling what you'll find on the jobsite or on the trail – so Bobcat makes machine protection features standard. Commonly available as optional equipment on other utility vehicles, the 3400D has built-in component protection to prevent damage in adverse conditions.

■ Built-in longevity

Liquid-cooled engine: our utility vehicle is equipped with a liquid-cooled engine to avoid overheating and protect critical components for a long life. It cools better than air at high RPMs for more power and performance.

Warning lights: easy to see, dash warning lights indicate low oil pressure and high coolant temperature, alerting the operator to shut down the engine before permanent damage occurs.

Easy service access: the fuel tank is conveniently located for easy refuelling. Daily checks of items such as the air filter and engine oil are easy and quick.

Maintaining your machine for top performance is simple with the 3400D.



CV GUARD: protects the half-shaft grease boots from damaging debris.

RADIATOR GUARD: reduces the risk of damage to the radiator.

SKID PLATE: protects the undercarriage, engine and transmission from branches, rocks and other debris as well as when travelling over rough, uneven terrain.

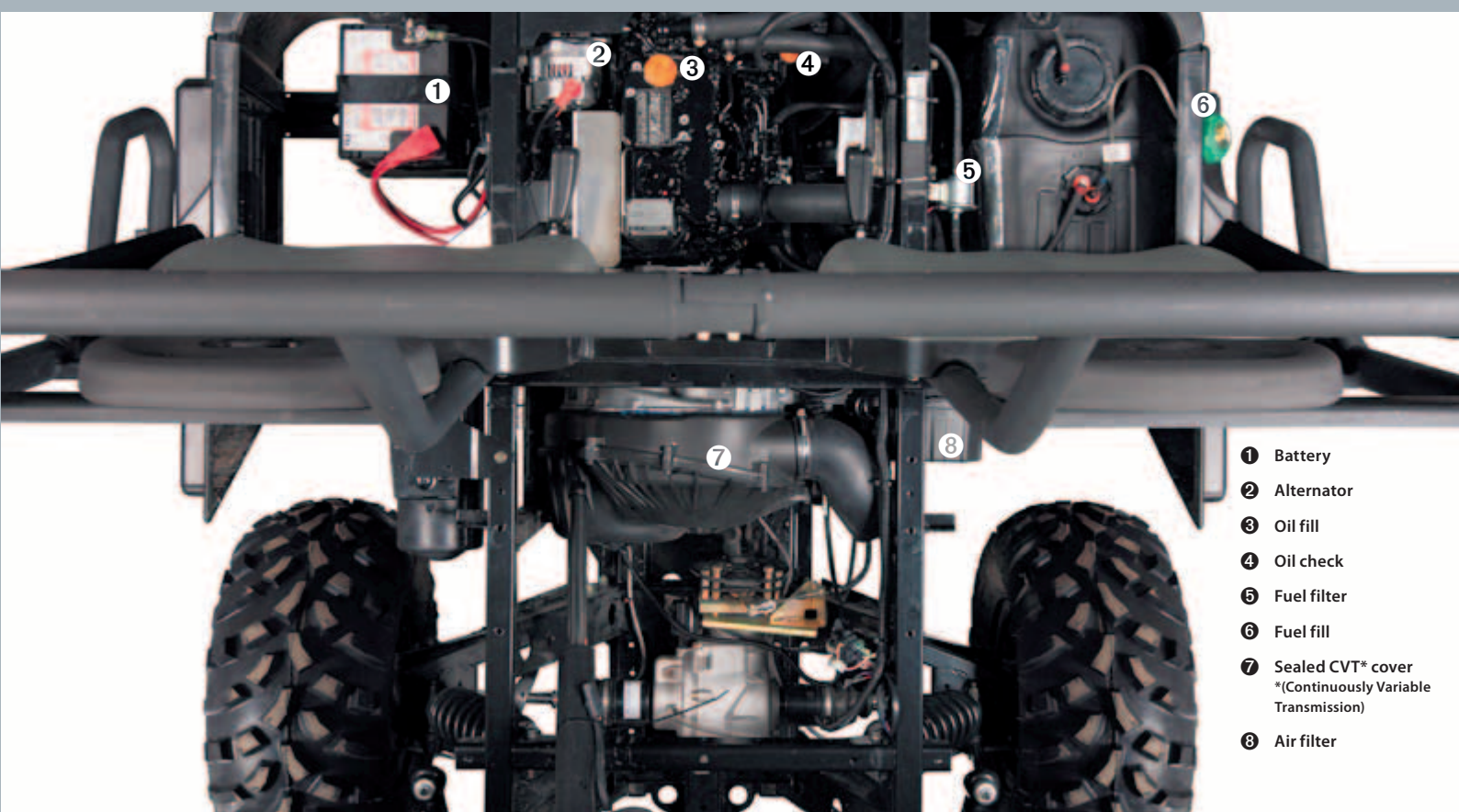

- 1 Battery
- 2 Alternator
- 3 Oil fill
- 4 Oil check
- 5 Fuel filter
- 6 Fuel fill
- 7 Sealed CVT* cover
*(Continuously Variable Transmission)
- 8 Air filter

Dealer-installed kits

Make it your own. Customize your Bobcat utility vehicle for the jobs you do – or tailor it to your personal style – with plenty of accessories and kits. Face extreme weather, accomplish various tasks and make your machine stand apart from the crowd.



Cab and heating: your activity doesn't stop when bad weather hits. Choose the dealer-installed cab to protect you from the elements, and if it is really cold, you can have your dealer install a heating to stay comfortable.

- Heated cab ①
- Radio ②
- Strobe light ③
- Nerf bar ④
- Integrated accessory system ⑤
- Vertical tool holder ⑥

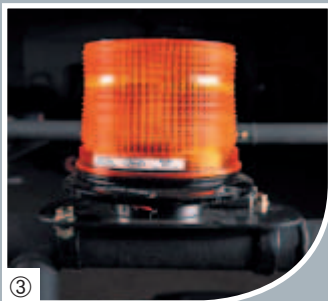

Protects the sides of the vehicle and the wheels.

Allows the use of a variety of easy-to-secure accessories.

Versatile cargo box: helps you haul supplies and materials with ease.

- Single latch allows you to open the tailgate with one hand
- Tilt cargo box with Lift Assist makes lifting the cargo box easier
- Optional electric powered lift (available on the Deluxe version) allows you to easily lift the cargo box – at the touch of a button from the driver's seat – to dump a full load conveniently.



Electrical accessories include a strobe light and back-up alarm for safer operation. Add cargo box accessories, such as the grass trimmer rack or cargo box divider to accommodate different requirements.

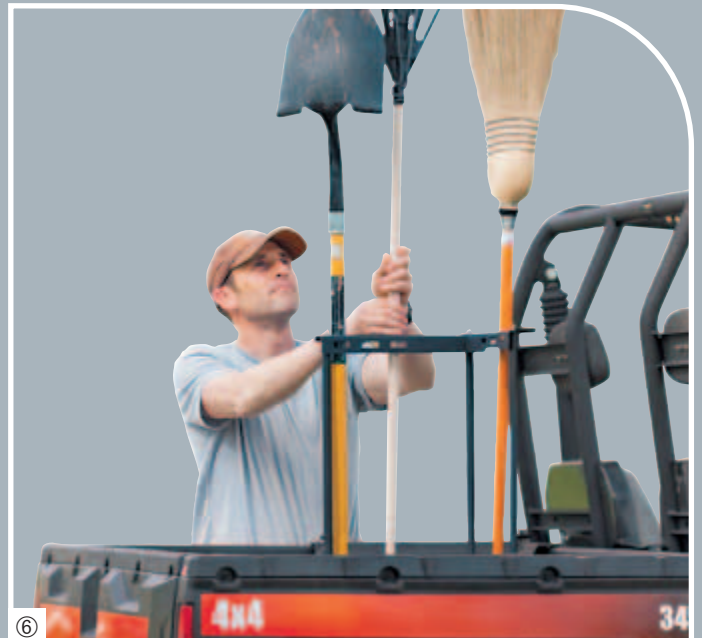

⑥

34

Machine Rating

Maximum trailer hitch coupler weight	68 kg
Maximum cargo box load	500 kg
Tow weight	680 kg
Vehicle rated capacity	725 kg
Total rated capacity	1406 kg
Max. travel speed — forward (low range)	24 km/h
Max. travel speed — forward (high range)	48 km/h
Max. travel speed — reverse	24 km/h

Engine

Make / Model	Yanmar 3TNM72-APL
Fuel / Cooling	Diesel / Liquid
Power (SAE J1349) @ 3600 RPM	18.2 kW
Maximum torque at 2500 RPM (SAE J1349)	53.6 Nm
Number of cylinders	3
Displacement	904 cm ³
Fuel tank capacity	34.1 L

Weights

Operating weight (full tank + driver)	730 kg
---------------------------------------	--------

Controls

Vehicle steering	Self-adjusting rack and pinion
Travel speed	Foot pedal. Forward/reverse travel direction is selected by a lever on the dashboard (high/low/neutral/reverse).
Drive modes	Four-wheel drive, two-wheel drive (differential locked), turf (differential unlocked)

Drive System

Transmission	Torque converter with 6:1 ratio in low range and 3:1 ratio in high range ; CVT (continuously variable transmission)
--------------	---

Standard Features

Steel frame	Toolkit
Lockable rear differential	Radiator guard
Four-wheel drive	Skid plate to protect undercarriage
Gear selector R-N-L-H	CV guard
Front suspension, MacPherson strut	12 V power outlet
Rear suspension, double A-arm	Beverage holder, glove compartment
Sealed transmission cover	4-wheel, hydraulic brake discs
2 inch rear receiver hitch	3-point seatbelts with comfort strap
Headlights: high and low beam	4-point ROPS
Tail- and brake lights	All-terrain 25 x 11-12 tyres
Headrests	Cargo box with powered lift assist
Parking brake	Warranty: 12 months or 1000 hours (whichever occurs first)
Storage compartment	

Options

- Deluxe version, including:
- Brushguard
- Black rims
- Electric powered cargo box
- Dealer Installed Accessories
- Modular steel cab
- Canvas cab
- Plastic canopy
- Fixed or tip-out glass windshield
- Windshield wiper
- Heating
- Defroster
- Back-up alarm
- External mirrors
- Internal rear-view mirror
- Engine block heater
- Working lights
- Turn signals
- Horn
- Strobe lights
- Winch
- Auxiliary battery
- Radio and panel speakers
- Brush guard
- Exhaust purifier
- Chainsaw mount
- Cargo box divider
- Gas can mount
- Vertical tool holder
- Horizontal tool holder

Dimensions

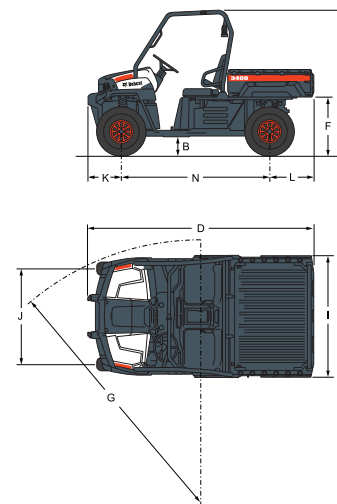

(B)	330 mm	(M)	395 mm
(C)	1905 mm	(N)	545 mm
(D)	2870 mm	(P)	241 mm
(E)	1930 mm	(T)	927 mm
(F)	787 mm		
(G)	1371 x 927 x 292 mm		
(H)	3048 mm		
(I)	3099 mm		
(J)	1524 mm		
(K)	1219 mm		
(L)	1245 mm		

Specifications and design are subject to change without notice. Pictures of Bobcat products may show other than standard equipment.

www.bobcat.eu



Bobcat®

