

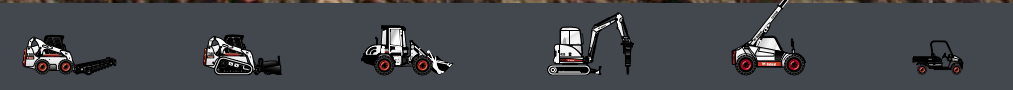

Bobcat®

T110

Compact Loaders



Machine Rating

Rated operating capacity, Bobcat	499 kg
Rated operating capacity, ISO 14397-1	505 kg
Tipping load	1443 kg
Pump capacity @ 91% efficiency	47.5 l/min
System relief at quick couplers	20.7 MPa
Travel speed	8.4 km/h

Engine

Make / Model	Kubota / V2403-M-DI-E3
Fuel / Cooling	Diesel / Liquid
Power	31.2 kW
Torque at 1400 RPM (SAE J1 995 Gross)	155.9 Nm
Number of cylinders	4
Displacement	2434 cm ³
Fuel tank capacity	45.2 l

Weights

Operating weight	2379 kg
------------------	---------

Controls

Vehicle steering	Direction and speed controlled by two hand levers
Loader hydraulics tilt and lift	Two foot pedals.
Front auxiliary (standard)	Lateral movement of the right-hand steering lever

Drive System

Transmission	Infinitely variable tandem hydrostatic piston pumps, driving two fully reversing hydrostatic motors
--------------	---

Standard Features

High-back cushion suspension seat	Instrumentation
Automatically activated glow-plugs	Lift arm support
Bob-Tach™ frame	Operating lights, front and rear
Bobcat Interlock Control System (BICS)	Parking brake
Deluxe operator cab	Seat belt
Includes interior cab foam, side, top and rear windows	Seat bar
Front door w/ windshield wiper	Spark arrestor muffler
Engine/hydraulics system shutdown	CE certification
Hydraulic bucket positioning	

* Roll Over Protective Structure (ROPS) – meets requirements of SAE-J1040 and ISO 3471; Falling Object Protective Structure (FOPS) - meets requirements of SAE-J1043 and ISO 3449, Level I

Options

Power Bob-Tach™	Deluxe instrument panel
Cab enclosure with heating	

Dimensions

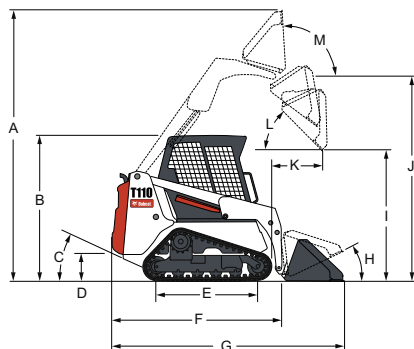

(A)	3474 mm	(J)	2634 mm
(B)	1882 mm	(K)	579 mm
(C)	37°	(L)	41°
(D)	201 mm	(M)	95°
(E)	1299 mm	(N)	1270 mm
(F)	2262 mm	(O)	1852 mm
(G)	2972 mm	(P)	949 mm
(H)	26°	(Q)	1199 mm
(I)	1999 mm		

Attachments

- Angle blade / Snow blade
- Angle broom*†
- Auger
- Backhoe
- Buckets (C/I & L/P)
- Digger
- Dumping hopper
- Mower
- Grapples and forks
- Hydraulic breaker**
- Landplane
- Pallet forks
- Scarifier
- Snow blower*
- Snow V-blade
- Soil conditioner
- Scraper
- Sweeper
- Three-point hitch
- Tiller
- Trencher

*Attachment control kit required.

**When operating the loader with this attachment, a Special Applications Kit, which includes a 12 mm Lexan front door with 6 mm top and rear windows, must be used.

†Optional water kit.



www.bobcat.eu